

Manual

High-Pressure Cleaner

HW 9185



Perfection is our aim

Wilms

WILMS HW 9185

Congratulations! We wish to thank you

for buying this cleaner. You have shown that you do not accept compromises: *you want the best.*

We have prepared this manual to enable to fully appreciate the qualities and high performance that this cleaner can offer you. Please read it completely before using the machine.

The **CE** mark on your cleaner shows that it has been constructed in compliance with the European Standards on safety.

We can also offer you a wide range of cleaning machines such as:

VACUUM CLEANERS, SCRUBBER DRYERS, SWEEPERS and a complete range of **ACCESSORIES** and **DETERGENTS** suitable for cleaning all kinds of surfaces.

Ask your Dealer for the complete catalogue of our products.

The text has been carefully checked, however any misprints should be notified to the manufacturer. The manufacturer also reserves the right to alter and update this publication without prior notice for the sake of product improvement.

All reproductions of this manual, in whole or in part, are forbidden without the manufacturer's authorization.

PREPARING THE CLEANER

Fitting the lance

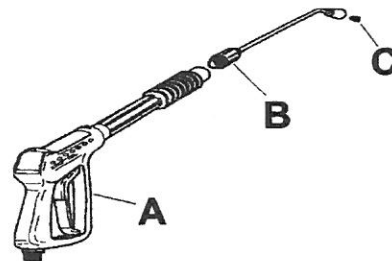

Water circuit connection.

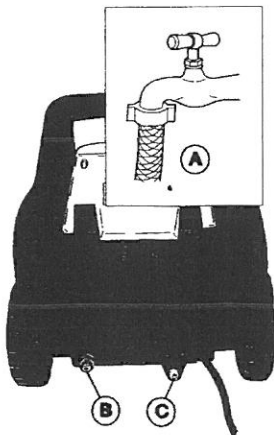

Electrical connection.

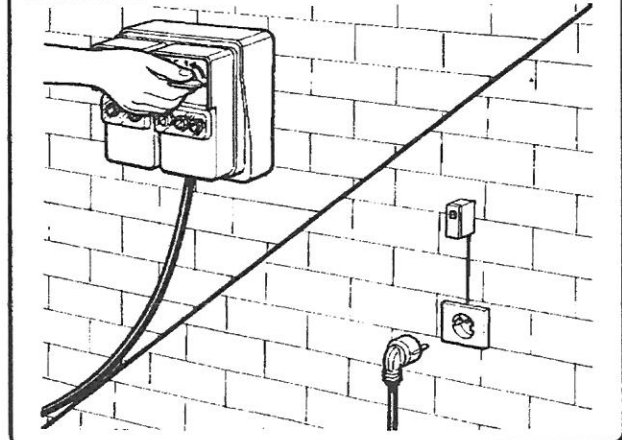

Continue reading this manual without connecting this cleaner to the power mains and the water supply.

WILMS HW 9185

DESCRIPTION OF SYMBOLS ON THE CLEANER

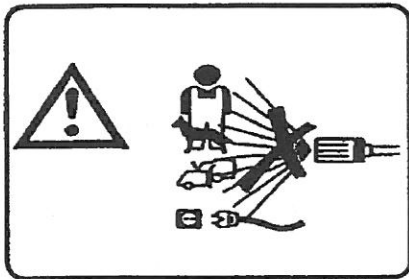

DO NOT DIRECT THE JET AGAINST PEOPLE, ANIMALS, POWER SOCKETS OR THE MACHINE ITSELF.

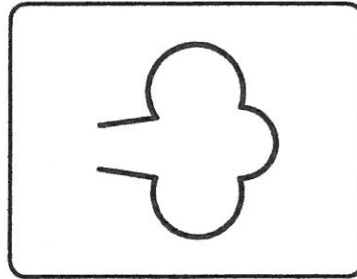

STEAM CONTROL.

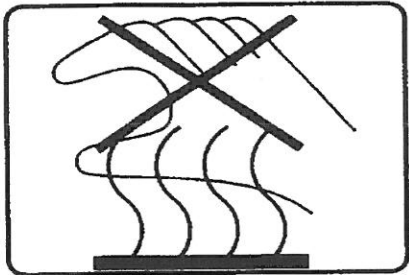

ATTENTION: RISK OF BURNS.

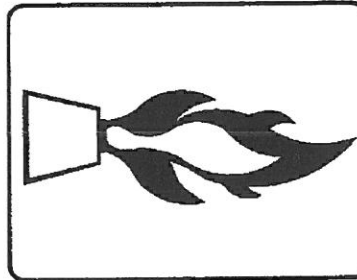

LIGHTING THE BURNER.

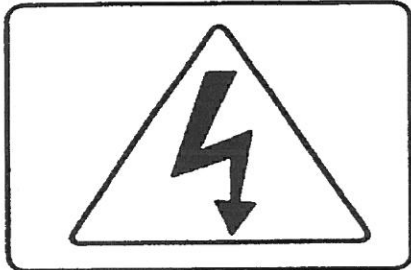

ATTENTION: RISK OF ELECTRIC SHOCK.

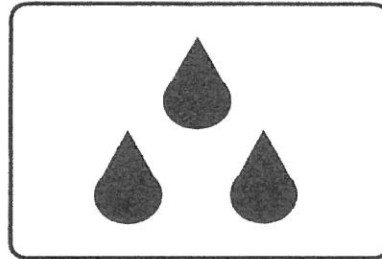

MICRO-LEAKS.

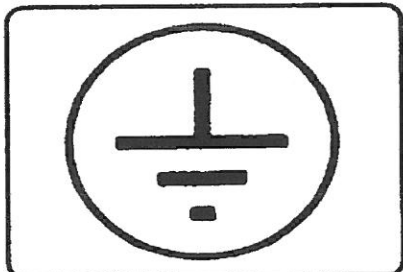

EARTH.

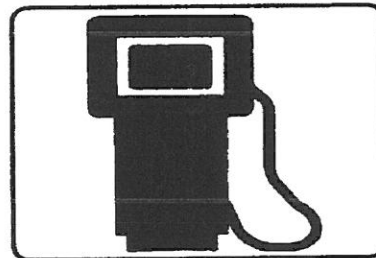

FUEL (DIESEL).

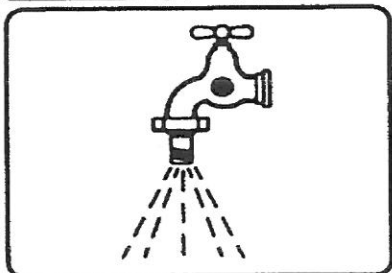

WATER INPUT.

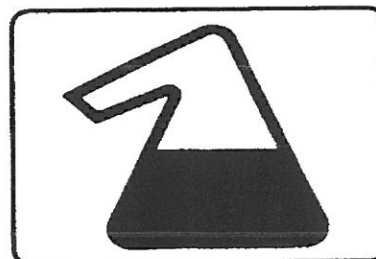

CHEMICALS (DETERGENT).

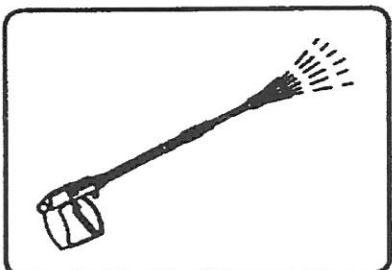

WATER OUTPUT.



ANTI-SCALE PRODUCT.

WILMS HW 9185

The most important instructions are marked with the symbol:



INTRODUCTION



This manual must be read before installing, setting up and using the cleaner. The manual is an integral part of the product. Read the warnings and instructions in this manual carefully as they provide important indications as to **SAFETY in USE and MAINTENANCE**, paying special attention to the general rules for safety.

KEEP THIS MANUAL CAREFULLY FOR FUTURE CONSULTATION.



The contents of this manual must be brought to the attention of persons using this high pressure cleaner and the staff responsible for maintenance.

CLASSIFICATION

The user must observe the conditions for use of the appliance prescribed by the Rules, and particularly he must respect the following classification:

As for the protection against electric shock, the high pressure cleaner belongs to **CLASS 1**.

The high pressure cleaner is factory set and all its safety devices are sealed. **It is forbidden to alter their adjustment values.**

In the Hot water cleaner the water is heated by a burner fed with **Diesel fuel**.

The high pressure cleaner must be always used on a firm and flat ground, furthermore it must not be moved while it is working or connected to the electric supply.

Failure to observe this prescription may cause danger for the user.

The high pressure cleaner must not be used in the presence of corrosive or potentially explosive atmospheres (vapours or gas).

The electric connection must be performed by qualified technicians who are able to work in observance of the governing rules and of the manufacturer's instructions.

A wrong electric connection may cause damage to persons, animals or things, and the manufacturer cannot be considered responsible for these.

The high pressure cleaners are equipped with a plug for connection to the electric supply.

In this case please check if the electric power system and the electric sockets are compatible with the max. power of the appliance indicated on the plate (kW).

In case of doubt, please apply to qualified personnel. If the socket and the plug of the machine are not compatible, have the plug replaced with a suitable type by qualified personnel.

Before connecting the machine make sure that the data indicated on the plate correspond to those of the electric supply.

The electric safety of this machine may be assured only when it is properly connected to an efficient grounding system in accordance with the governing laws for electric safety.

It is necessary to check this essential safety requisite. In case of doubt, ask for accurate control of the power system by qualified personnel.

The manufacturer may not be considered responsible for damages occurred because of the lack of the grounding system.

Failure to respect the above absolves the manufacturer of all liability and represents negligent use of the product.



High pressure cleaners with the „Total Stop“ device should be considered as off when the omnipolar switch is in the „0“ position or the plug is unplugged from the socket.

WILMS HW 9185

INTENDED USE

This appliance is intended exclusively for cleaning machines, vehicles, buildings and general surfaces suitable for treatment with a high pressure jet of detergent solution between 25 and 250 bar.

This appliance has been designed for use with the detergents supplied or recommended by the manufacturer. The use of other detergents or chemicals may influence the safety of the appliance.

This appliance must be used only for the purpose for which it was specifically designed.

All other uses are to be considered incorrect and therefore unreasonable.

Examples of unreasonable use:

- Washing surfaces not suitable for cleaning with a high pressure jet.
- Washing people, animals, electric equipment of the machine itself.
- Using unsuitable detergents or chemicals.
- Blocking the trigger (lever) of the lance in delivery position.

The manufacturer cannot be held responsible for any damage due to improper, incorrect or unreasonable use. As far as safety rules are concerned, the cleaners are manufactured according to the European Standard 60 335-1 (General standard) and EN 600335 2 79 (Specific standard).

PRELIMINARY OPERATIONS

UNPACKING

After unpacking, ensure that the cleaner is undamaged. If in doubt, do not use the machine. Contact your dealer.

Packaging (bags, boxes, nails, etc.) is potentially dangerous and should be kept out of reach of children. It should be disposed off or retained in respect of national environmental legislation.

FITTING THE SEPARATE PARTS OF THE MACHINE

All the fundamental parts and safety devices of the machine are assembled by the manufacturer.

For reasons of packing and transport, some secondary cleaner parts are supplied separately.

The user must fit these parts as explained in the instructions supplied in each assembly kit.

DATA PLATE:

The data plate bearing the main technical characteristics of your cleaner is located on the trolley and is always visible.



When buying your cleaner, ensure that it has an identification plate. If there is no plate, inform the manufacturer and/or the dealer immediately. Machines without a plate must not be used and the manufacturer declines all responsibility for them. Products without a plate must be considered anonymous and potentially dangerous.

FILLING THE FUEL TANK

Fill the tank with fuel for Diesel motors (fig. 1)



Do not use different fuel from that indicated on the identification plate. Check the fuel from time to time while the cleaner is operating. Attempting to use the cleaner without fuel may cause damage to the fuel pump.



FIG. 1

FILLING THE DETERGENT TANK

From the range of recommended products, choose the one most suited to the washing job to be done (fig. 2) and dilute it with water according to the instructions on the pack.

Fill the detergent tank with the diluted product (fig. 3).

Ask your dealer for the catalogue of the detergents that

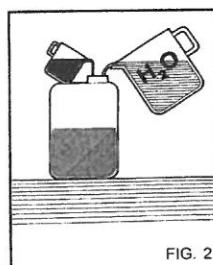

FIG. 2

can be used depending on the type of washing job to be done and the type of surface to be treated.
After using the detergent, the detergent intake circuit must be flushed out with clean water.

FILLING THE WATER SOFTENER TANK

Fill the tank with water softener solution. Use only products recommended by the manufacturer and/or dealer. Follow the instructions given on the packaging meticulously.

WATER CIRCUIT CONNECTION

Connect the feed hose to the mains (Fig.5A) and to the hosetail on the cleaner (Fig.5B).
Check that the pressure and quantity of the water supplied by the mains are sufficient for the cleaner to work properly: (2 to 8 bar).
Maximum temperature of feeding water 50 ° C (122° F).

Connect the high pressure hose to the cleaner (Fig.5C) and to the lance (Fig.6).

IMPORTANT:

The cleaner must operate with clean water. Dirty or sandy water, corrosive chemicals and solvents can cause severe damage to the cleaner.

Failure to respect the above absolves the manufacturer of all liability and represents negligent use of the product.

ELECTRICAL CONNECTION

Connection of the cleaner to the mains must be carried out by skilled technicians able to ensure that all regulations in force are complied with use in respect of current standards and legislation.

Ensure that the mains voltage available is the same as the voltage at which the cleaner is supposed to work (this is indicated on the identification plate).



The electric cable must be protected from accidental crushing.



Do not use the machine if the supply cable is damaged.



The use of any electric appliance requires the respect of some basic rules:

- Do not touch the appliance with wet or damp hands or feet.
- Do not use the appliance bare-footed or with unsuitable clothing.
- Do not pull the supply cable or the appliance itself in order to disconnect the plug from the electric supply.

As for the protection against electric shock, the high pressure cleaner belongs to **CLASS I**.





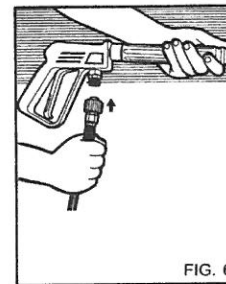
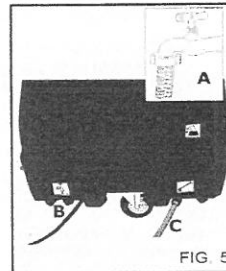
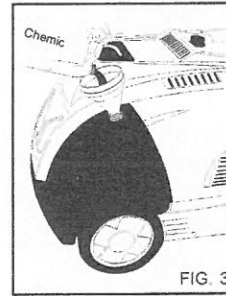





Failure to observe the above warning frees the manufacturer from all responsibility and constitutes negligent use of the product.









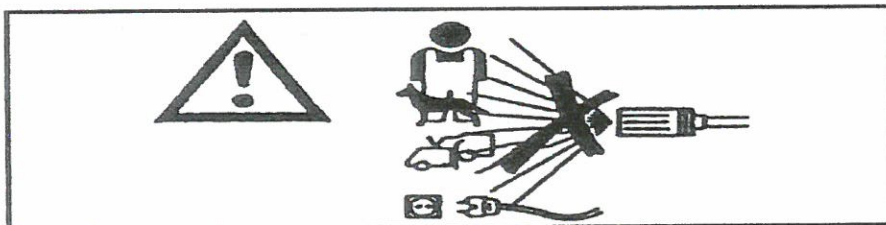





WILMS HW 9185

GENERAL WARNINGS ABOUT INSTALLATION AND USE

-  The use of any electric appliance requires the respect of some basic rules:
 - Do not touch the appliance with wet or damp hands or feet.
 - Do not use the appliance bare-footed or with unsuitable clothing.
 - Do not pull the supply cable or the appliance itself in order to disconnect the plug from the electric supply.
-  The H.P. cleaner must not be used by children, teen-agers or incapable persons (under the influence of alcohol, etc.)
-  Use only original accessories that can allow safe working of the appliance.
-  The flexibel hose connecting the lance to the H.P. cleaner must not be damaged. In case of damage, replace it immediately.
-  Hoses, connections and fittings for high pressure systems are very important to guarantee the safety of the H.P. cleaner. Use only original spare parts which have the manufacturer's approval.
-  Do not use the H.P. cleaner when persons or animals are in its action field.
-  High pressure jets may be dangerous if not properly used. The jet must never be directed at persons or animals, electric appliances or at the appliance itself.
-  The high pressure water jet causes a reaction power on the lance. Hold the lance grip vigorously.
-  The use of the H.P. cleaner must be considered according to the kind of washing which must be performed. Protect yourself against the ejection of solid materials or corrosive substances by means of adequate protective clothing.



-  The use of the H.P. cleaner must be considered according to the place where the washing is performed (for example: food plants, pharmaceutical plants, etc.) Pertinent rules and safety conditions must be followed.
As for the protection against electric shock, the H.P. cleaner belongs to **CLASS I**.
-  Do not direct the water jets at your own or other people's body in order to clean clothes or shoes.
-  While working it is forbidden, to block the trigger (lever) of the lance in delivery position.
-  In the hot water H.P. cleaners a Diesel fuel burner is used for water heating. The use of other fuels is dangerous.
-  Before starting any cleaning or maintenance operation, disconnect the machine from the electric and water supply networks.
-  Periodically, at least once a year, have the safety devices checked by one of our service centres.
-  If the appliance is to be used in an enclosed space, install a exhaust fame extraction system and guarantee adequate ventilation.
-  The hot water cleaner must be supervised while it is working.
-  Do not clog the openings or the ventilation grilles and the heat and smoke extraction systems in the hot water cleaners.
-  Do not use the machine if the supply cable is damaged.
-  The electric power cable must never be under mechanical tension and must be protected against accidental crushing.
-  In case of damage or malfunction, switch off the appliance (disconnecting it from the water main and from the electricity main via the omnipolar switch).

USING THE CLEANER

CONTROL PANEL

- A – On/Off switch
- B – Temperature regulator
- C – Detergent control tap
- D – Light indicating connection to the mains/microleakages
- E – Light indicating diesel oil lack
- F – No descaler indicator light
- G – No detergent indicator light
- H – Pressure gauge
- I – Steam control

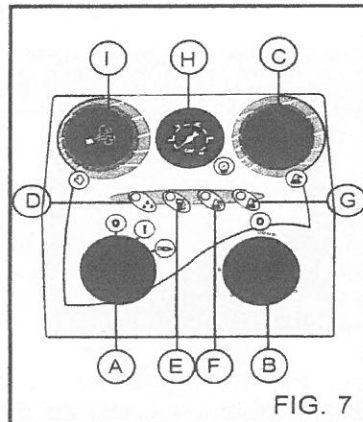

STARTING THE CLEANER

- 1) Turn on the water supply tap (fig. 5A).
- 2) Connect the water cleaner to the mains electricity supply via the omnipolar switch or by plugging the plug into the socket.
- 3) Start the cleaner by turning the selector switch to pos. 1 (fig. 7A).
The high pressure water jet generates a reaction force in the lance. Keep a firm grip on the lance handle.
- 4) Press the trigger on the gun and begin washing.
- 5) To use the cleaner with hot water, turn the temperature regulator (fig. 7B) to the recommended washing values.
Turn the ignition switch (fig. 7A) onto the hot water position before effecting the operations described in this point.

 In water cleaners with the „Total Stop“ system, the motor starts and stops when the lever on the lance handle is pulled or released.

 Do not block the handle lever in the delivery position.

IMPORTANT!

To eliminate any impurities or air bubbles from the water circuit we advise starting the cleaner for the first time without the lance and letting the water run out for a few seconds. Impurities could block the nozzle and cause malfunction (fig. 8).

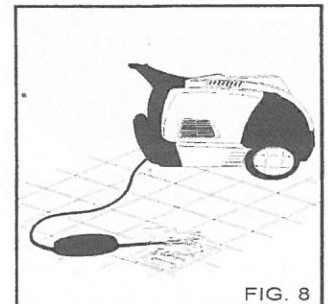





FIG. 8

STOPPING THE CLEANER

- 1) Switch off the burner by turning the thermostat regulator to pos. „0“ (fig. 7B).
- 2) Let the cleaner run with cold water only for at least 30 seconds to cool down the boiler.
- 3) Stop the cleaner by turning the selector switch to pos. „0“ (fig. 7A).
- 4) Discharge the pressure from the H.P.hose by pressing the trigger on the gun.
- 5) Disconnect the water cleaner from the mains electricity supply via the omnipolar switch or by unplugging the plug from the socket.
- 6) Turn off the water supply tap (fig. 5A).

 If the water cleaner is left, even temporarily, turn it off by using the omnipolar switch or by unplugging the plug from the socket.

 Water cleaners with the „Total Stop“ device should be considered as off when the omnipolar switch is in „0“ position or the plug is unplugged from the socket.

 When the water cleaner is not used, close the safety device on the handle (fig. 10).



Dry use of the water cleaner causes serious damage to pump gaskets.

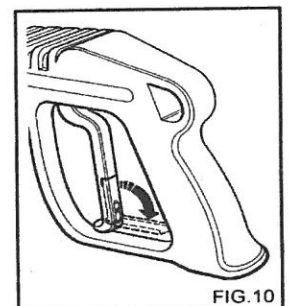
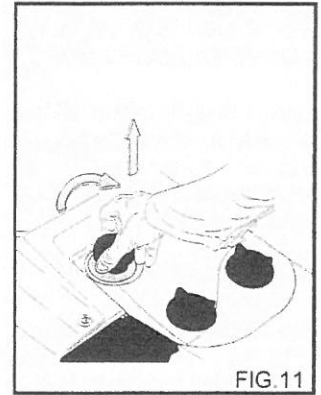

FIG. 10

WILMS HW 9185

REGULATING PRESSURE AND USING STEAM

Turn the thermostat knob „B“ (fig. 7) (140°C – 284°F) to steam position to obtain an increase in the temperature of the water at delivery.
To operate the steam control, turn the steam tap anticlockwise to open the steam (fig. 11).



At work temperatures then are higher than 95°C (203°F), the working pressure must be between 5 and 32 bar.

Steam boiler regulation

Test pressure and design are according to the steam boiler regulation and TRD 801.



**During use with boiling water, „Steam Phase“, keep away from the openings for fumes discharge (risk of burning).
When you have finished using the „Steam Phase“, turn the thermostat knob „B“ to position „0“ (fig. 7) and let the machine cool down for about 3 minutes with the gun turned on.**

Turn the steam tap clockwise again to shut off the steam.

ADVICE ON USING DETERGENTS

This cleaner has been designed for use with the detergents supplied or recommended by the manufacturer. The use of other detergents or chemicals may influence the safety of the cleaner.

- 1) For environmental compatibility, we recommend a reasonable use of detergents, according to the instructions on the pack.
- 2) From the range of recommended products, choose the one most suited to the cleaning job to be done and dilute it with water according to the instructions on the pack or in the catalogue of the detergents most suited for the type of hot or cold water cleaner.
- 3) Ask for our detergent catalogue.

OPERATING PHASES FOR CORRECT CLEANING WITH DETERGENTS.

- 1) Prepare the solution of detergent at the concentration most suitable for the type of dirt and the surface that is to be washed.
- 2) Start the cleaner, turn on the detergent tap, and spray the dirty surface with the diluted product, working from bottom to top. Let it react for a few minutes.
- 3) Rinse the whole surface well from top to bottom with hot or cold water at high pressure.
- 4) After use with detergent, rinse the high pressure water circuit by operating the pump for one minute with the detergent tap completely closed.

MAINTENANCE

**ONLY THE OPERATIONS AUTHORIZED IN THIS INSTRUCTIONS MANUAL MAY BE CARRIED OUT BY THE USER.
ALL OTHER OPERATIONS ARE FORBIDDEN.**



For maintenance of the boiler, high pressure pump, the electrical parts and all parts with a safety function, please apply to our technical service centre.
Disconnect the water cleaner from the mains electricity supply via the omnipolar switch or by unplugging the plug from the socket and close the water supply tap (see chapters on connecting to the electricity and water mains) before carrying out any maintenance jobs. Once maintenance has been completed, ensure that the closing panels have been correctly reassembled and anchored with the screws provided before reconnecting the cleaner to the mains.

Failure to do so may cause a risk of electric shock!

PRECAUTIONS AGAINST FROST

The cleaner must not be exposed to frost.

If the cleaner is left in premises where it is exposed to frost, when work is over or for storage, antifreeze must be used to prevent serious damage to the hydraulic circuit.

WILMS HW 9185

OPERATIONS FOR USING ANTIFREEZE

- 1) Turn off the water supply (tap), disconnect the hose and run the cleaner until it is completely empty.
- 2) Stop the water cleaner with the ON/OFF switch in the „O“ position.
- 3) Fill the water tank with antifreeze solution.
- 4) Start the water cleaner with the ON/OFF switch in the „I“ position.
- 5) Start the cleaner and let it run until antifreeze comes out through the lance.
- 6) Suck up antifreeze with the detergent intake system too.
- 7) Disconnect the water cleaner from the mains electricity supply via the omnipolar switch or by unplugging the plug from the socket.

CHECKING PUMP OIL LEVEL AND OIL CHANGE

From time to time check the oil level in the high pressure pump by means of the sight glass (fig. 13A) or the dipstick (fig. 13B).

If the oil has a milky appearance, call the technical service centre immediately.

Change the oil after the first 50 hours' work and subsequently every 500 hours or once a year.

Proceed as follows:

- 1) Unscrew the drain cap situated under the pump (fig. 13C).
- 2) Unscrew the cap with the dipstick (fig. 13).
- 3) Let all the oil drain off into a container and deliver it to an authorized oil collection and disposal centre.
- 4) Replace the drain screw and pour fresh oil in through the filling cap on top (fig. 14A) until it reaches the level indicated on the sight glass (fig. 14B).

Use only SAE 15 W/40 oil!

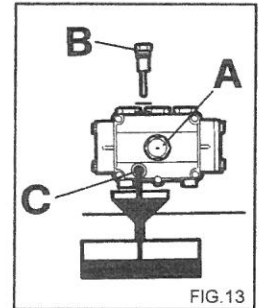

CLEANING THE FUEL FILTER AND TANK.

Remove and replace the inline fuel filter (fig. 15). Change it from time to time.

Empty the fuel tank.

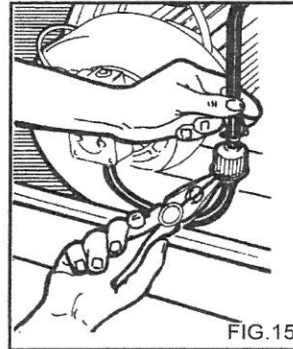

Open the drain cap (fig. 16) and let any impurities drain out into a container. Flush out the tank with clean fuel and close the drain cap.

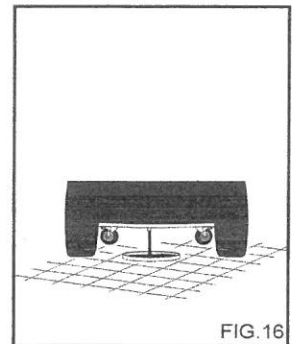

CLEANING THE WATER FILTER.

Clean the water intake filter regularly and free it from impurities (fig. 17).



CHANGING THE NOZZLE

The high pressure nozzle fitted on the lance must be changed from time to time, as this component is subject to normal wear during use. Wear may generally be detected by a drop in the working pressure of the high-pressure-cleaner. To replace it, consult your supplier for instructions.

DESCALING

Descaling must be carried out from time to time because the scale present in the water partially desposits inside the hydraulic circuit and the coil which with time becomes clogged.

Apply to our technical service centre to have the machine descaled from time to time; this will save you money and increase the efficiency of the cleaner.

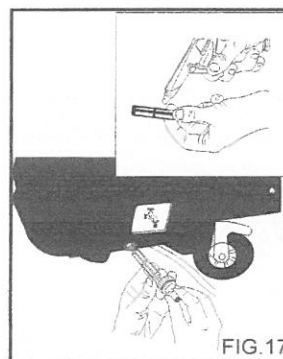

WILMS HW 9185

TABLE OF ROUTINE MAINTENANCE TO BE PERFORMED BY THE USER

Description of operations:

Check power cable, pipes, high pressure connectors	Each use
1. oil change in H.P.pump	After 50 hours
Subsequent changes in H.P.pump	Every 500 hours
Change and clean fuel filters	Every 100 hours
Clean fuel tank	Every 100 hours
Clean water filter	Every 50 hours

TABLE OF EXTRAORDINARY MAINTENANCE TO BE PERFORMED BY THE TECHNICAL SERVICE CENTRE

Description of operations:

Boiler:

Clean coil	Every 200 hours
Descale coil	Every 300 hours
Clean fuel pump	Every 200 hours
Change fuel nozzle	Every 200 hours
Regulate electrodes	Every 200 hours
Change electrodes	Every 500 hours
Change seals on H.P.pump	Every 500 hours
Change lance nozzle	Every 200 hours
Calibrate and check the safety devices	Once a year

IMPORTANT:

These intervals refer to normal working conditions. For heavy duty use decrease the interval for each job.
For maintenance and/or repairs, use only original spare parts which offer the greatest characteristics of quality and reliability. Failure to use original spare parts absolves the manufacturer from all liability and transfers it to the person carrying out the operation.

PERIODS OF INACTIVITY

If the machine is to remain inactive for a long period, disconnect the supply sources, drain the tank(s) of all the operating fluids and protect any parts that could be damaged by the accumulation of dust.
Grease the parts that could be damaged by drying out, such as the supply hoses. When bringing back into use, ensure that there are no cracks or cuts in the water supply hoses.
Oil and chemical products must be disposed off according to current legislation.

SCRAPPING

If you decide that the cleaner is no longer to be used, render it inoperative by removing the electric power cable. Ensure that all parts of the cleaner that could be a source of danger are made harmless, especially for children who might use the old cleaner for play. As the cleaner is considered special waste, dismantle it and divide the material according to type, then dispose of them as required by the legislation in force.

Do not use parts dismantled for scrap as spare parts.

WILMS HW 9185

TROUBLE-SHOOTING



Before carrying out any operations, disconnect the water cleaner from the mains electricity supply via the omnipolar switch or by unplugging the plug from the socket!

FAULTS	CAUSES	REMEDIES
When the ON-OFF switch is turned the cleaner does not start.	Faulty electric connection. Thermal protection has tripped.	Check the mains voltage. Reset (if it trips again, apply to the technical service centre).
No jet or leakage from high pressure water circuit. After 30 seconds, the water cleaner stops.	Water supply filter clogged. Faulty connection to the mains water supply. Mains water supply tap closed. Leakage from high pressure circuit.	Clean. Check. Open. Contact Service Centre.
The pump functions but does not reach rated pressure.	Water supply filter clogged. Faulty connection to the mains water supply. Pressure regulation valve is set at minimum. Lance nozzle worn. Valves dirty or worn. Detergent tap open. Pressure adjustment devices on lance open.	Clean. Check. Regulate it. Contact Service Centre. Contact Service Centre. Close. Close.
When the lance is open, the pressure drops and rises.	Nozzle clogged or deformed. Inadequate water supply. Detergent tap open.	Clean or contact Service Centre. Check. Close.
In by-pass or total stop phase, the high-pressure cleaner shuts down.	Micro-leaks of water from the high pressure circuit.	Contact Service Centre.
After the total stop phase, the water cleaner does not start up and the red indicator light is on.	The water cleaner has been unused for at least 20 minutes and is in a state of total shutdown.	Restart by rotating the main switch „A“ (fig.7) into the „O“ position and subsequently into the „I“ position.
When the temperature regulator is brought to the required position, the burner does not start.	No diesel.	Check the level of diesel in the tank and make sure the fuel supply circuit is free of water.
Fifteen seconds after start up, the cleaner stops and indicator light „D“ (fig.7) flashes with an acoustic signal.	Motor rotation direction incorrect on three-phase models.	Contact Service Centre.

WILMS HW 9185

FAULTS	CAUSES	REMEDIES
Water not hot enough.	Temperature regulator position. Filters clogged. Boiler element coated with scale.	Check. Clean or replace. Contact Service Centre.
Excessive smoke coming out of chimney.	Incorrect combustion. Fuel contaminated with impurities or water.	Clean or replace diesel filters. Contact Service Centre. Empty the tank and clean thoroughly.
Insufficient detergent suction.	Tap closed. No detergent. Element or tube clogged.	Open. Fill the detergent tank. Contact Service Centre.
Indicator light „F“ (fig.7) flashes with an acoustic signal.	Water softener solution empty.	Fill the tank.
Water leakage from head.	Gaskets worn.	Contact Service Centre.
Water in the oil.	Excessive humidity in atmosphere.	Replace oil.

To reset the indicators, rotate the main switch „A“ (fig. 7) to the pos. „0“ and then to the „I“ position.

WILMS HW 9185

TECHNICAL SPECIFICATIONS HW 9185

Type:	HW 9185
Max. water volume:	14 l/min.
Max. operating pressure:	200 bar
Working-pressure:	40-180 bar
Working-temperature:	30-135 °C
Voltage:	400 V / 50 Hz (3-phase)
Rated current:	10 A
Fuse:	16 A
Water-pump:	3-piston high-pressure pump
Motor with overheat protection:	400 V – 50 Hz – 6,0 kW (3-phase)
Oil burner:	robust – widely maintenance-free
Burner nozzle:	1,35 G 60° S
High-pressure hose:	10 m
Permitted water nozzles:	25045
Dimensions: L X W X H	1050 x 700 x 880 mm
Weight:	110 kg
Noise level: according to EN ISO 11201	dB (A) 78,8

SPARE PARTS LIST

HW 9185 according to drawing 1

<u>Pos.</u>	<u>Order-No.</u>	<u>DESCRIPTION</u>	<u>Qty.</u>
1	3310140	Chassis	1
2	3310001	Wheel	2
3	3308208	Locking Ring	2
4	3310002	Hub Cap	2
5	3310141	Nut	2
6	3308310	Swivel wheel with break	1
7	3309013	Strain relief bushing	1
8	3310142	Tank	1
9	3310143	Detergent tank	1
10	3310144	Gasket	4
11	3308113	Drain Plug	4
12	3309009	Nut M 39 x 3	4
13	3310008	Tank cap	3
14	3310145	Handle complete	1
15	3310146	Tank for softener solution	1
16	3310147	Support	1
17	3310148	Support	1
18	3310149	Control Box bottom	1
19	1138911	Gasket	1
20	3310150	Support	1
21	3310151	Control Box Lid	1
22	3310232	Decal	1
23	3309714	Terminal Block	1
24	3310152	Knob till 02 / 2008	1
24	3310233	Knob from 02 / 2008	1
25	5908137	Locking Ring	2
26	3310153	Cap	1
27	3309402	Bushing	1
28	3309209	Sealing Ring	1
29	3309121	Transition Plate	1
30	3309206	Bushing for On- and Off-Switch	1
31	3309208	Sealing Ring	1
32	3309016	Knob	3
33	3310154	Cover right	1
34	3310155	Cover left	1
35	3310157	Cover – white	1
36	3310158	Cover	1
37	3310159	Cap	2
38	6557611	High-Pressure Hose	1
39	3310090	Handle	1
40	3308218	Lance	1
41	3307129	Nozzle 1/4" - 25045	1
42	3310160	Flap	1
43	3310230	Fuse holder	2
44	3310231	O-Ring 22,22 x 2,62	1
45	3309227	O-Ring 18,72 x 2,62	1

Drawing 1

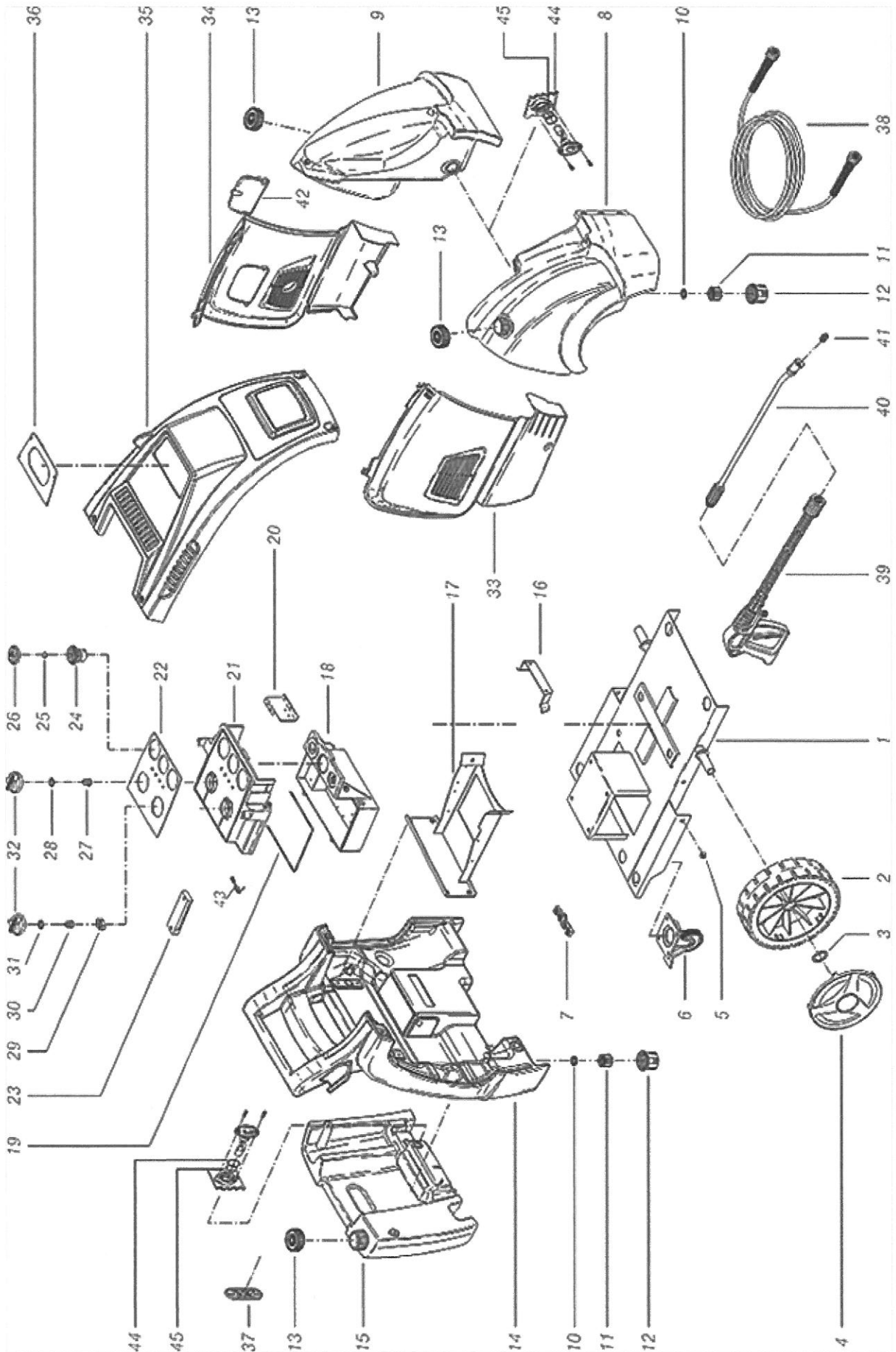

S P A R E P A R T S L I S T

HW 9185 according to drawing 2

<u>Pos.</u>	<u>Order-No.</u>	<u>DESCRIPTION</u>	<u>Qty.</u>
1	1139024	Coupling	1
2	1139022	Reducer	1
3	1139021	Gasket	1
4	3310030	Nut	1
5	3309621	Water Filter	1
6	3307106	Gasket 1/2"	1
7	3310161	Hose	1
8	3310033	Floater	1
9	3308103	Hose Clamp 16 – 29 mm	1
10	3310162	Hose	1
11	3310234	Gasket	1
14	3310163	Nipple 3/8" x 3/8" from 2004	1
15	1133381	Water Filter 1/2"	1
16	3310164	Hose	1
17	3309735	Gasket	2
18	3309736	Hollow screw 1/2"	1
19	3310165	Pump	1
20	3310166	Flange	1
21	3310167	Coupling	1
22	3310168	Motor	1
23	1133190	O-Ring 13,95 x 2,62	1
24	3309031	Nipple 3/8" x 3/8"	1
25	3310183	Hose	1
26	3300074	Double nipple 3/8"	2
27	1370170	Gasket 3/8"	2
28	3310181	Valve till 06 / 2010	1
28	3310235	Valve from 06 / 2010	1
29	3310169	Hose	1
30	3308193	Dipping Pipe	1
31	3308192	Spring	1
32	3310170	Hose	1
33	3309071	Nut M 26 x 1,5	1
34	3300158	Reducing Piece 3/8" – 1/8"	1
35	3310172	Reducing Piece 1/2" – 1/8"	1
36	5914324	Gasket 10 x 14 x 1 1/8"	8
37	3310174	Hose till 02 / 2008	2
37	3310236	Hose from 02 / 2008	1
38	3310284	Hose from 02 / 2008	1
39	3310173	Screw	4
40	3310175	Valve till 02 / 2008	1
40	3310237	Valve from 02 / 2008	1
41	3309035	Nut 1/2"	1
42	3310176	Elbow till 02 / 2008	1
42	3310238	Elbow from 02 / 2008	1
43	3310177	Hose till 04 / 2007	1
43	3310239	Hose from 04 / 2007	1
44	3310178	Gauge	1
45	3310179	Valve	1
46	3309134	Hose Clamp	4
47	1370182	Injector hose 6 – 12	2,2 m
48	3309135	Body	1

SPARE PARTS LIST

HW 9185 according to drawing 2 – page 2

<u>Pos.</u>	<u>Order-No.</u>	<u>DESCRIPTION</u>	<u>Qty.</u>
50	3309266	O-Ring 4,48 x 1,78	1
51	3309137	Adjuster	1
52	3309138	Gasket	1
53	3309718	Spring	1
54	3310180	Suction line	1
55	3311080	Plastic Hose	0,72
56	3309237	O-Ring 6,75 x 1,78	1
57	1138039	Nozzle	1
67	3300108	O-Ring 5,28 x 1,78	1
68	3309658	Connecting Nipple	1
69	3310184	Valve Body	1
70	1138159	Ball	1
71	3309112	Spring 8 x 5,3	1
72	1133327	O-Ring 10,82 x 1,78	2
73	3310185	Housing	1
74	3308079	O-Ring 11,11 x 1,78	1
75	3309785	Plug	1

Drawing 2



SPARE PARTS LIST

HW 9185 according to drawing 3

<u>Pos.</u>	<u>Order-No.</u>	<u>DESCRIPTION</u>	<u>Qty.</u>
1	3309071	Nut M 26 x 1,5	2
2	3309073	O-Ring 15,54 x 2,62	2
3	3309072	Support Ring	2
4	3310186	Bottom	1
5	3310187	Insulation	1
6	3310188	Locking Ring	1
7	3310189	Tape	1
8	3310190	Coil	1
9	3310191	Cylinder	1
10	3310192	Outer Housing	1
11	3310193	Pin	3
12	3310194	Burner Cone	1
13	3310195	Electrode Holder	1
14	6162694	Burner Nozzle 1,35 GPH – 60° S	1
15	3310196	Nozzle Holder	1
16	3307059	Electrode	1
17	3309751	Inspection Glas	1
18	3309752	Circlip	1
19	6161601	Elbow	2
20	3309753	Ignition Cable	2
21	3309144	Connection Cable	1

Drawing 3

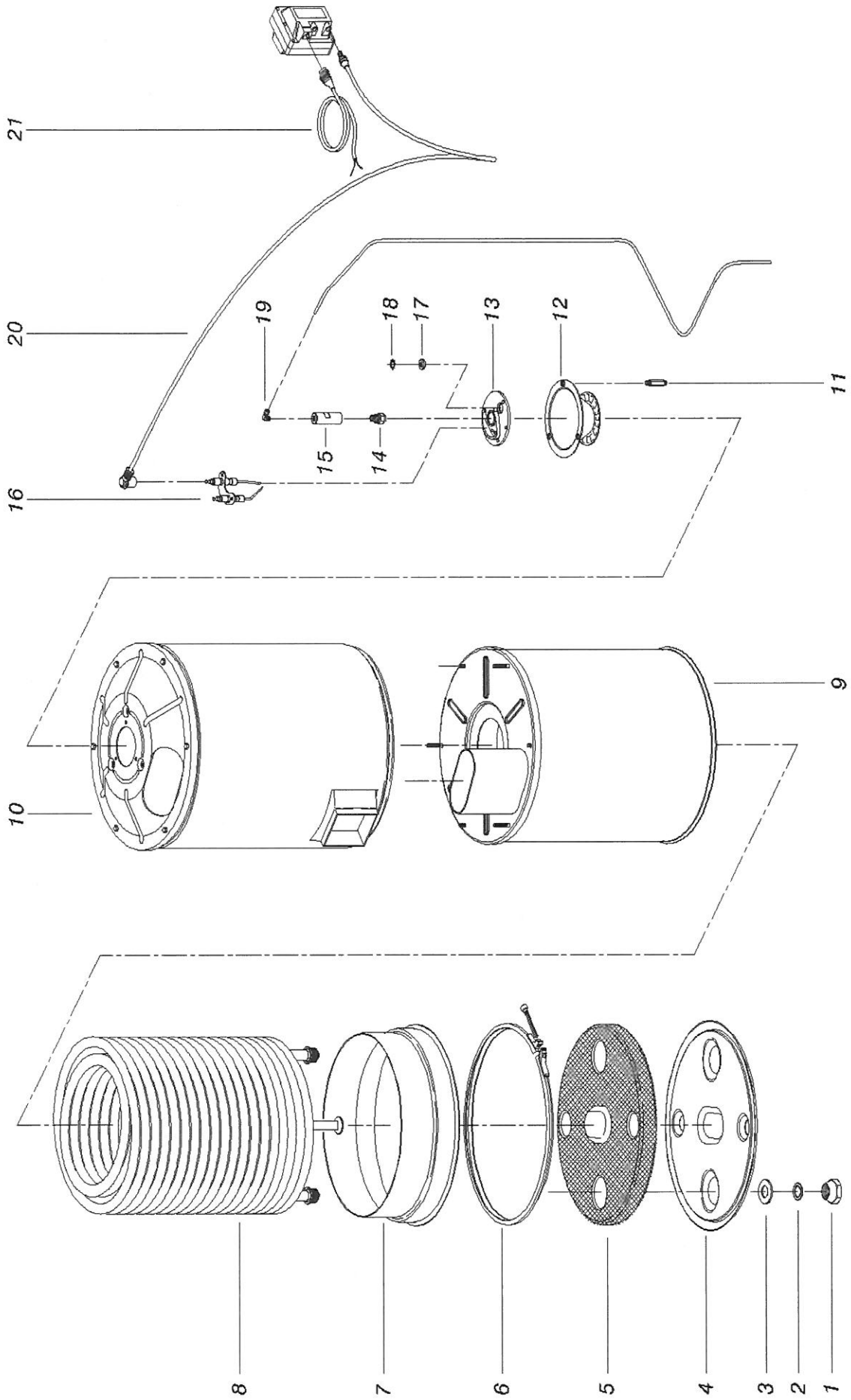

SPARE PARTS LIST

HW 9185 according to drawing 4

<u>Pos.</u>	<u>Order-No.</u>	<u>DESCRIPTION</u>	<u>Qty.</u>
1	3310200	Collar till 06 / 2006	1
1	3310240	Collar from 06 / 2006	1
2	3310201	Clamp till 06 / 2006	1
2	3310241	Clamp from 06 / 2006	1
3	3310202	Housing left side	1
5	3310203	Blower Wheel Motor	1
6	3310208	Bushing	1
7	3310204	Washer	1
8	3310205	Bushing	1
9	3310206	Blower Wheel	1
10	3310207	Housing right side	1
11	3310209	Air Flap	1
12	3309088	Clamp	7
13	3310210	Coupling	1
14	3310211	Pump	1
15	3300064	Connecting Nipple – 1/4" x 7 mm	2
16	3309134	Hose Clamp	4
17	3308075	Fuel Hose	2,2
18	3310064	Clamp	2
19	3309768	Filter	1
20	3310180	Suction	1
21	3310212	Suction	1
22	3310065	Nipple	1
23	3310213	Pipe Nozzle Holder	1
24	3310214	Cable – Solenoid Valve	1

Drawing 4

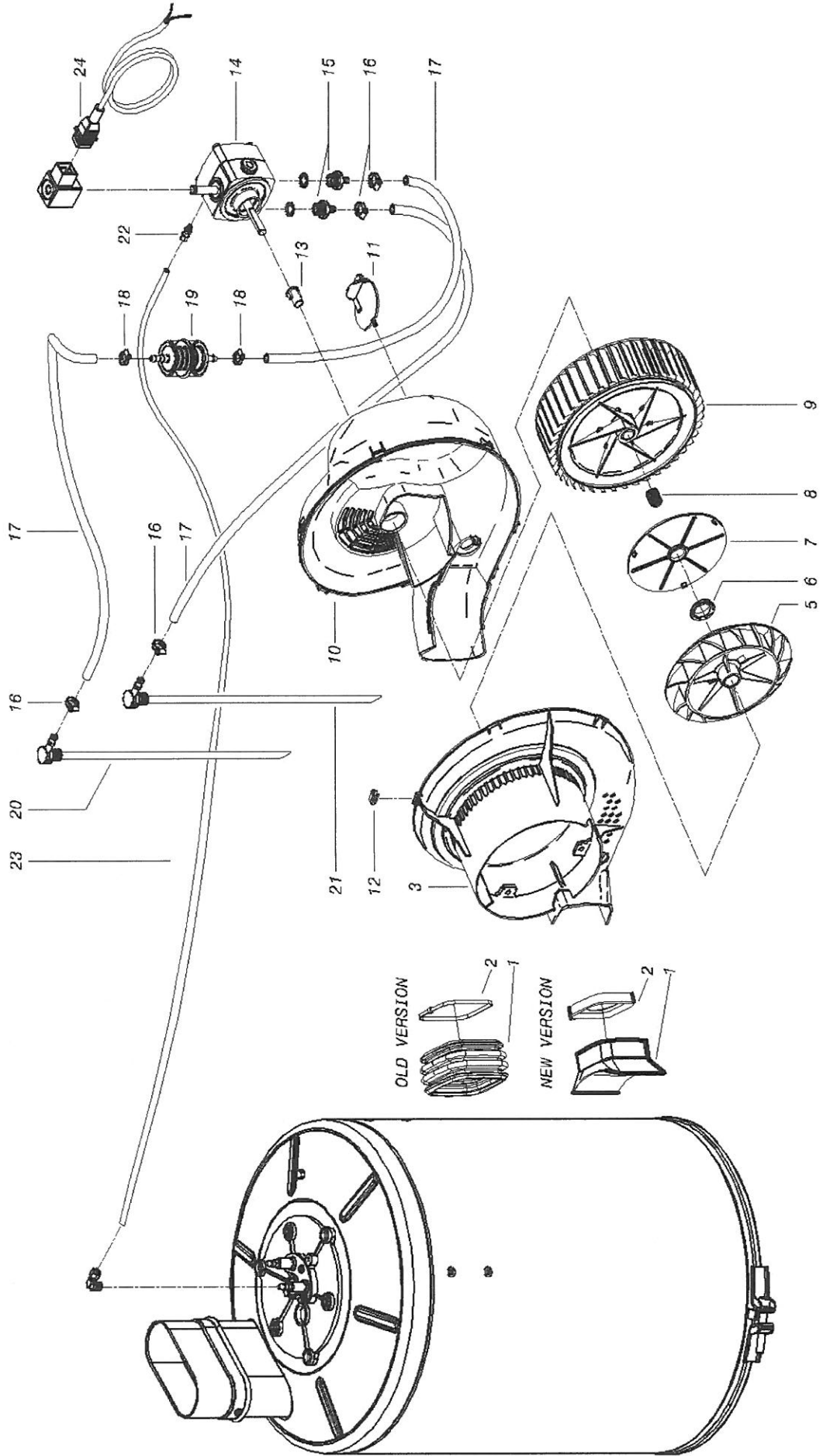

SPARE PARTS LIST

HW 9185 according to drawing 5

<u>Pos.</u>	<u>Order-No.</u>	<u>DESCRIPTION</u>	<u>Qty.</u>
K	3309150	Relais	1
EC	3310215	Control	1
EV	3309766	Coil till 01 / 2005	1
EV	3310072	Coil from 02 / 2005	1
F1	5914233	Fuse till 11 / 2002	1
F1	3310216	Fuse from 11 / 2002 – 12 / 2003	1
F2	3307149	Fuse till 12 / 2003	1
G2	3310217	Float Switch	1
IG	3310218	Switch	1
LC	3309155	Radio Shielding Filter	1
P1	3310073	Pressure Switch	1
P1	3310219	Pressure Switch from 03 / 2003	1
P2	3310074	Pressure Switch	1
PA	3310220	Proportioning Pump	1
RT	3310221	Motor-Protective Switch	1
TA	3309143	Ignition Transformer	1
TH	3309297	Thermostat 0 – 150° C	1
TR	3308217	Low Voltage Transformer till 02 / 2008	1
TR	3310242	Low Voltage Transformer from 02 / 2008	1
TS	3308224	Thermostat 50° C	1
CV1	3310222	Power Supply Cable	1
F1,2	3308030	Fuse from 12 / 2003	2
G1,3	3310243	Float Switch till 05/ 2008	1
G1,3	3310223	Float Switch from 05/ 2008	1

Drawing 5

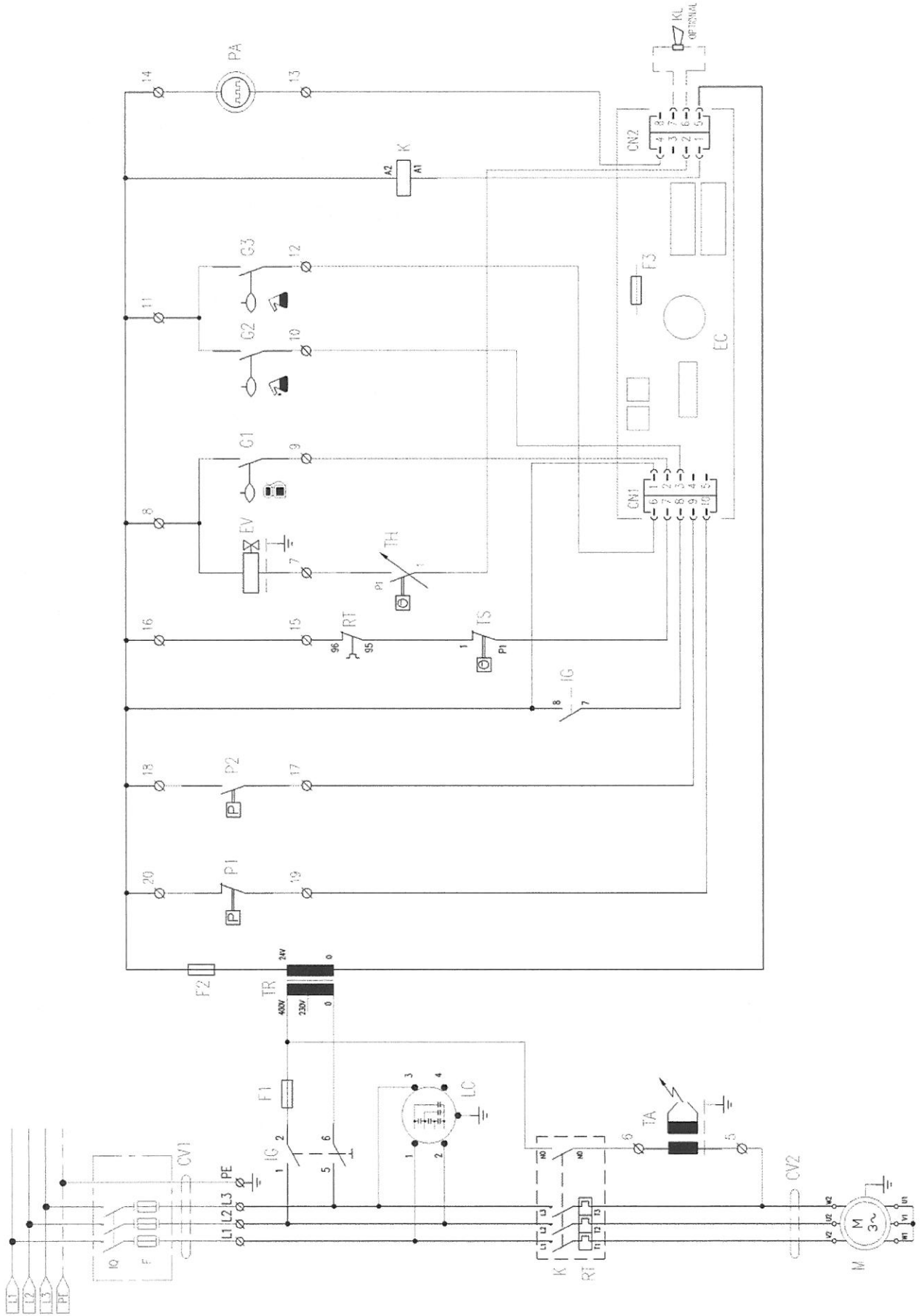

SPARE PARTS LIST

HW 9185 according to drawing handle

<u>Pos.</u>	<u>Order-No.</u>	<u>DESCRIPTION</u>	<u>Qty.</u>
1	3310126	Pin	2
4	3310121	Cup right till 04 / 2008	1
4	3310244	Cup right from 05 / 2008	1
5	3310133	Spacer	1
6	3310132	Lance till 04 / 2008	1
6	3310245	Lance from 04 / 2008	1
8	3310127	Plate	1
9	3310123	Trigger	1
10	3310124	Screwing	1
11	3310137	O-Ring 9,3 x 2,4	1
12	3310135	Nipple	1
13	3310136	Ring	1
14	3310130	Insulation	1
15	3310134	Screwing	1
16	3310246	Nut	1
17	3310247	Nipple till 04 / 2008	1
17	3310248	Nipple from 04 / 2008	1
18	3310249	Connecting Piece	1
19	3310254	Kit 26 – 14	1
21	3310251	Piston	1
22	3310120	Cup left till 04 / 2008	1
22	3310252	Cup left from 05 / 2008	1
23	3310128	Pipe	1
24	3310253	O-Ring	1

Drawing Handle

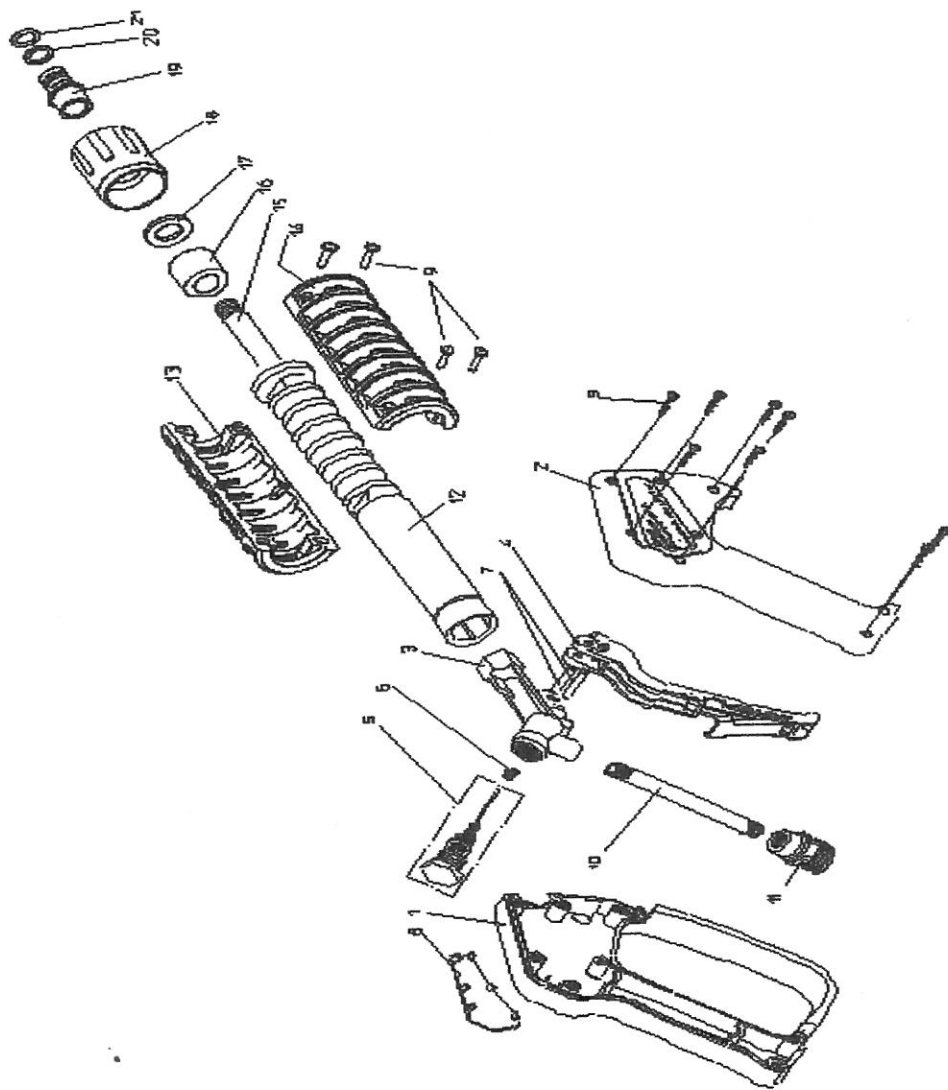

SPARE PARTS LIST

HW 9185 according to drawing pump

<u>Pos.</u>	<u>Order-No.</u>	<u>DESCRIPTION</u>	<u>Qty.</u>
1	3310255	Pump Head	1
2	3310256	Screw M 8 x 65	8
3	1133232	Washer 8,4 x 13 x 0,8	8
9	1133208	O-Ring 20,24 x 2,62	6
10	1138741	Locking Screw	6
11	1138742	Valve	6
12	1133317	Screw M 6 x 10	8
13	1133318	Lid	2
14	1138731	Spacer	1
15	1133320	O-Ring 55,56 x 3,53	1
16	1138073	(Lager) Bearing	2
17	3310257	Gasket Ring	3
18	3310258	(Kurbelgehäuse) ?? Crank Housing?	1
19	1133323	Oil Level	1
20	3310259	Crank Shaft	1
21	3310293	(Keil) ??	1
22	3310260	Piston Lead	3
23	3310261	Connecting Rod	3
24	1138737	O-Ring 101,27 x 2,62	1
25	3310262	(Gehäusedeckel) Lid for Housing	1
26	1133326	Screw M 6 x 14	4
27	1133236	O-Ring 10,82 x 1,78	1
28	3300110	(Stopfen) Plug	2
29	3310263	Pin	3
30	3310264	Washer 9 x 25 x 0,5	3
31	1138055	Support Ring	3
32	3310265	O-Ring 5,28 x 1,78	3
33	3310266	Piston	3
34	3310267	Washer 8 mm	3
35	1138052	Nut	3
36	1138740	Gasket Ring	1
40	3310268	Ring	3
41	3310269	O-Ring 28,30 x 1,78	3
42	3310270	Collar	3
43	3310271	Transition Ring	3
44	3310272	Collar	3
45	1133256	Plug 3/8 x 13	1
46	1133254	Plug 1/2 x 10	1
47	1139074	Gasket Ring	1
48	1133255	Gasket Ring	1
49	3310273	Oil Inspection Glas	1
50	3310274	O-Ring 25,58 x 3,53	1
51	3310275	O-Ring 11,11 x 1,78	1
52	3310276	Nipple	1
53	3310277	O-Ring 14 x 1,78	1
54	1138360	Support Ring	1
55	1138177	O-Ring 9,92 x 2,62	1
56	1138368	Valve Seat	1
57	1138367	Screw M 5 x 10	1
58	1138366	Valve	1
59	1138358	O-Ring 6,75 x 1,78	2
60	1138744	Protection Ring	1
61	1138745	O-Ring 21,01 x 1,78	1
62	1138746	Valve Lead	1

SPARE PARTS LIST

HW 9185 according to drawing pump

<u>Pos.</u>	<u>Order-No.</u>	<u>DESCRIPTION</u>	<u>Qty.</u>
63	1138747	Valve	1
64	1138748	Spring	1
65	1138749	Spacer	1
66	1138362	Support Ring	1
67	1138750	Control Piston	1
68	1138152	O-Ring 9,13 x 2,62	1
69	1138751	Support Ring	1
70	1133182	O-Ring 23,81 x 2,62	1
71	1138752	Bushing	1
72	1138753	Spring Plate	1
73	1138754	Spring 7,6 x 29	1
74	1138354	Spring 15 x 35	1
75	1138353	Spring Plate	1
76	1138352	Cap	1
77	3300122	O-Ring 20,35 x 1,78	1
78	1138351	Screw M 8 x 20	1
	3310278	Kit 15 – 123 consisting of item 11	
	1138791	Kit 15 – 124 consisting of item 9 + 10	
	1138792	Kit 137 consisting of item 54/55/56/57/58/59/60/61/62/63/64/65/66 67/68/69.	
	3310279	Kit 15 – 159 consisting of item 17	
	3310280	Kit 15 – 161 consisting of item 42 + 44	
	3310281	Kit 15 – 163 consisting of item 40	
	3310282	Kit 15 – 165 consisting of item 43	
	3310283	Kit 15 – 167 consisting of item 40/41/42/43/44	

Drawing Pump

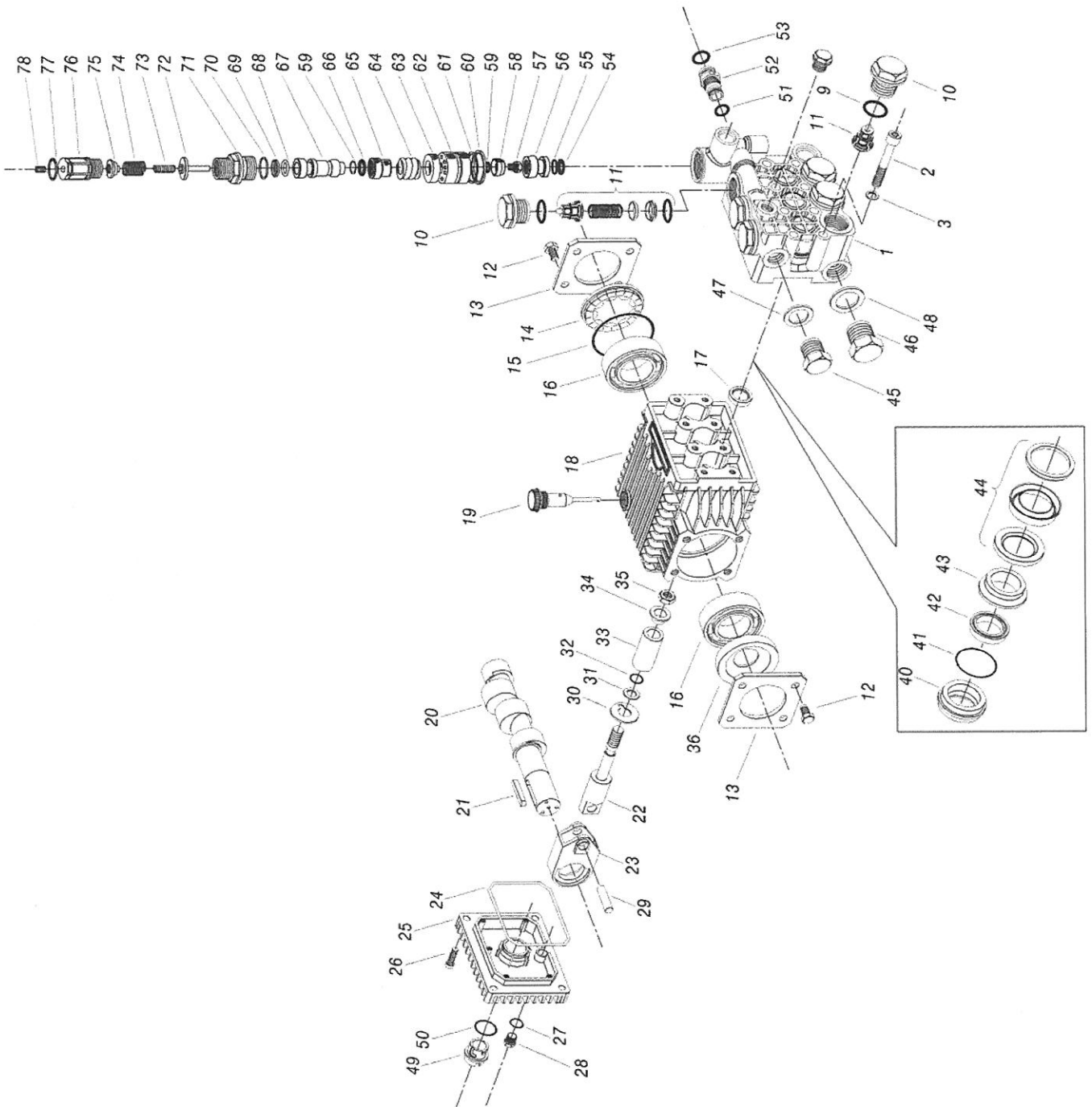

SPARE PARTS LIST

HW 9185 according to Pressure relief valve

<u>Pos.</u>	<u>Order-No.</u>	<u>DESCRIPTION</u>	<u>Qty.</u>
1	3310285		1
2	1139032	O-Ring 15,6 x 1,78	1
3	3309776	O-Ring 10 x 1	1
4	3310286	Valve Seat	1
5	3310287	Housing	1
6	3309784	(Gegenmutter) Nut	1
7	3310288	O-Ring	1
8	3309776	Support Ring	1
9	3309780	Piston	1
10	3310289	Ball	1
11	3310290	(Druckscheibe) Thrust Washer	1
12	3310291	Spring	1
13	3310292	Cap	1

